



HARDIK PRECISION

Automotive Industries LLP

Manufacturer & Trading (Import and Export)

One stop solution for all your needs for all industry

We offer the complete purchase salutation to our customers worldwide on very competitive price according to the customer needs



OUR COMPANY



NEA KUASU MOLD TEC GMBH

Mittlere-Motsch-Straße 20 | 96515 Sonneberg |
Deutschland

- Prototype Mold Making & Parts production
- After sales service for Series tool

HPAI KUASU China MFG.

Kangle RD | ShanXia cun Industrial zone
| Hengli Town | 523460 Dongguan | P.R.
China

- Injection & Die casting Molds Making
Factory
- Production injection molding

KUASU MOLDS GERMANY GMBH

Garden-City-Str. 2 | 96450 Coburg |
Deutschland

- Sales & Marketing
- Project Management

HARDIK PRECISION AUTOMOTIVE INDUSTRIES LLP (INDIA)

Plot . No. 06, Gali No-5 , E-Block Rayan Enclave,
Bhondsi, Sohna Road, Gurgaon, Haryana India -
122102

- Sales & Marketing
- Project Management
- After Sales services for series tool

Kuasus Precision Molds HK Ltd

Flat/RM H | 15/F SiuKing Bldg
6 | On Wah St. | Ngau Tau
Kok, Kowloon | Hong Kong

- Financing & Investment

OUR TEAM



- ◆ Working system:
2 Shifts, 6 days per week,
flexible depends on project.

- ◆ 10 Management,
25 Designers,
58 Tool makers,
11 Project managers,
12 QC members.

We are manufacture & Trading (Import and Export) high precision and quality Molds & products from India & worldwide. And we have sales and engineering & manufacturing plants in India, China, & Germany. HPIL has two separate division manufacturers & Trading.





Greetings from HPAI

Welcome to **HARDIK PRECISION AUTOMOTIVE INDUSTRIES LLP**. We are manufacture & Trading (Import and Export) high precision and quality products from India & worldwide. And we have sales and engineering & manufacturing plants in India, China, & Germany. HPIL has two separate division manufacturers & Trading. Kuasu is Founded in 2003 & HPIL Founded in 2016. HPIL Kuasu has been quietly cultivating the mold and injection molding industry for 20 years, becoming a respected company in the field.

HPIL has expertise manufacturing in mold design and making high-quality heat sink , plastic injection mold, Sheet metal mold, Thermos forming & Vacuum forming mold as class “A” molds. With the experienced team, HPIL offers solutions for complex in supplying Functional and aesthetic Mold & Part to the Automotive and Appliance industry **HPIL believes in continuous Innovation and some of the new technologies. We have an in-house tool designing facility.**

HPIL has expertise manufacturing Material & Packing Solutions: – PP Boxes, Crates & Bins, Foldable Small & Jambo Bins, Plastic Pallets, HDPE Partition, Racking Systems, PP Box, PP tollies & EPE & EVA foam fitment & foam cavity. Foldable wire mesh Containers & Foldable racking systems, Nestainer & Corrugated Boxes & PP Box Customized according to the needs of customer Etc..

Manufacturer



One stop solution for all your needs for all industry

TOOLING & DIE SOLUTIONS	MATERIAL HANDLING SOLUTIONS
1:-INJECTION MOLDS	1:- PLASTICS BIN & CRATES
2:-SHEET METAL MOLDS	2:- PP BOX - BINS
3:-BLOW MOLDS	3:-CUSTOMIZED PP BOX
4:-PLASTICS PARTS	4:-FOLDABLE WIRE MESH CONTAINER
5:-SHEET METAL PARTS	5:-PLASTIC DUSTBIN & FLOWERPOT
6:- HEAT SINK (ALU-COPP)	6:-FOLDABLE SMALL AND JUMBO BIN
7:- WATER OVERFLOW STOPPER	7:- NESTAINER
	8:-CORRUGATED BOX

HEAT SINK (ALU-COPP) :-Focus on the challenges and pressures that customers pay attention to, provide competitive cooling solutions and services, and continue to create maximum value for customers. 2. Mission and pursuit: let customers obtain never and better technology, (1) make customers satisfied; (2) Successful implementation of commitments; (3) Interdependence

Trading Solution



1:-Industrial Hardware Product, 2:- Industrial Safety Product, 3:- Electrical & Electronic Product

We have separate team location wise & worldwide for Any type of product in any industry just like Industrial Hardware , Electrical & Electronic, Metals like SS, Aluminum, MS, any types of Jig fixtures and Gauges Etc. Any type of Industrial product in any Industry for Import & Export required form India or from worldwide. We have complete solution. Search the Good quality supplier in all over world & Supply to best product with complete compliances to our customer.

We offer the complete purchase salutation to our customers worldwide on very competitive price according to the customer needs.

We adhered to the goal of **“To bring you the highest quality products at the best possible pricing”**. And our management policy is **“Quality first, customers centered”**.

OUR YIELD

**Automotive , Auto Ancillary
FMCG, Home appliance
Electronic Products
Beverage, connectors
any industry Etc.**

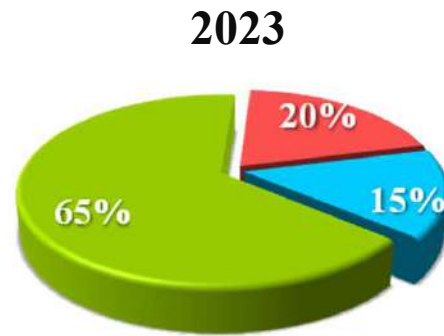

■ Europe

■ North America

■ Domestic Market

■ Europe

■ North America

■ Domestic Market

Volume

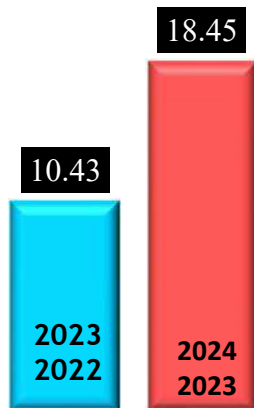

Million USD

Capability For Molds Building



IN HARDIK PRECISION AUTOMOTIVE INDUSTRIES LLP HAVE NEVER CAPACITY CONSTRAINTS.



OUR

PRODUCT HEAT SINK

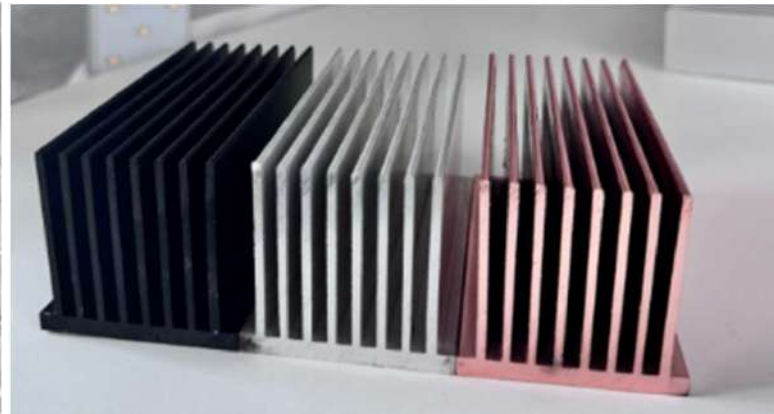
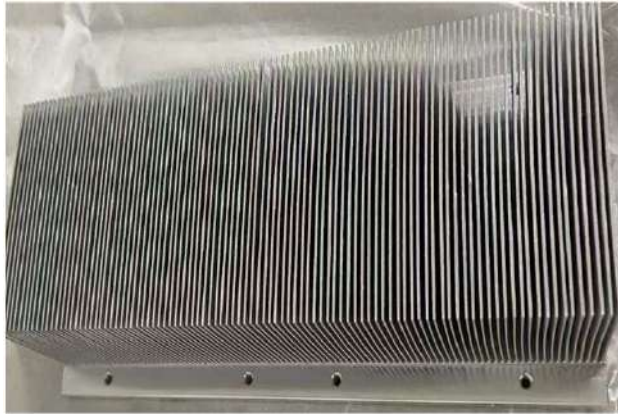

1. More heat dissipation area can be obtained in unit volume.
2. The length and width are not limited, more than 700mm can be used for friction welding.
3. The tooth thickness is 0.05~2.0mm, and the step distance is 0.25~7.5mm, which can be made according to the thermal simulation results.

OUR

PRODUCT HEAT SINK



Photovoltaic inverter (high-power aluminum extruded radiator or shovel tooth buried pipe)



LED radiator (High performance heat pipe radiator)

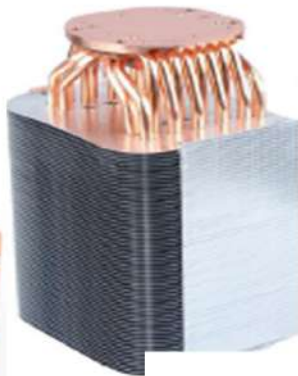

OUR

PRODUCT RANGE CIVIL



HPIL has expertise manufacturing designed UPVC and System Aluminum Windows and Doors . HPIL high performance products add an architectural dimension to your home and keep out street noise, dust, mosquito, pollution, rain, and wind. Its solutions outlast buildings. HPIL has good quality products for your building. All types of material like Foldable mesh; SS304-Mesh; MS-MESH; PVC strip, Magnetic strip, Polyester / Pet Thread cord, Silicon spray, color spray Weather Seal, Door Seal, in Fabric & Paper , Aluminum section, we can customize according to customer requirements.

OUR

PRODUCT RANGE PACKING



HPIL was initiated with the basic designing of the packing materials. HPIL manufactures Polypropylene Corrugated Sheets box , fabricated products, molded crates under one roof. HPIL is manufacturing P.P. fabricated, like PP BINS, PP BOX (Foldable & Non-Foldable), PP CASE, HDPE BINS, Crates Fabrication products which are marketed to Industrial Customers of different fields some of which includes automotive based industries, logistics-based industries, electronics-based industries, health care sector, PR organizations, Construction fields, Agriculture sector etc.

Salient Features:

Light Weight, Strong, Waterproof, Chemical Proof, Vermin Proof , Recyclable, Reuse, Printable, live Hinge, High Insulation, Easy Fabrication, Impact Resistant, Puncture Resistant, Tearing Resistant, Custom Made,

OUR

PRODUCT TRADING & MFG

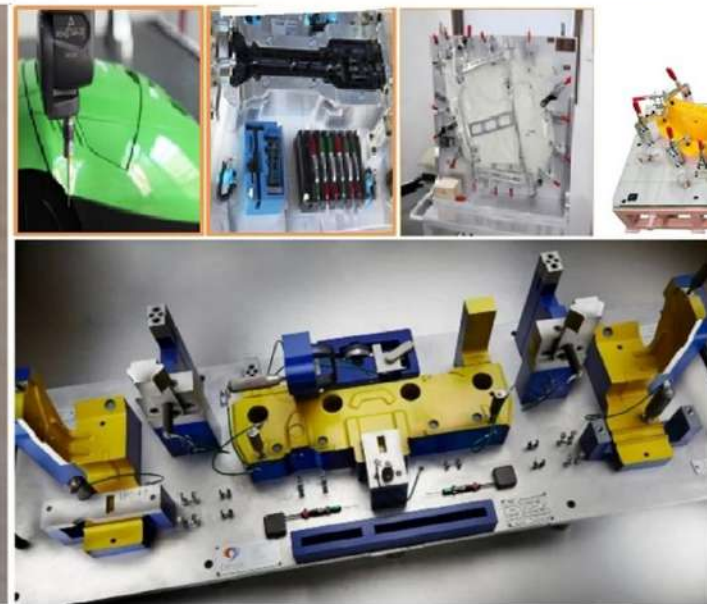
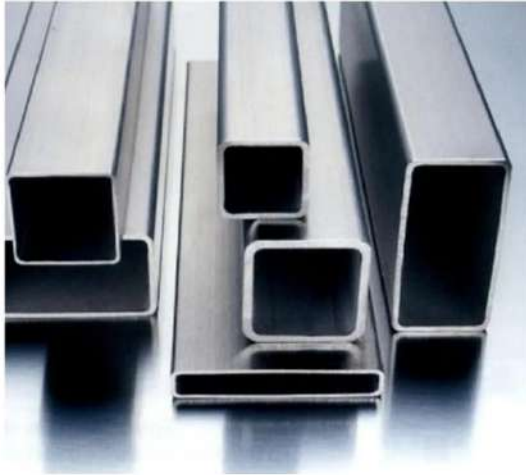

WATER OVER FLOW STOPPER

SAVE RESOURCES
USE THE GREEN FUTURE

WOFs

WATER OVER FLOW STOPPER

WOFs

HPAZ

Main Wire
Neutral Wire

WOFs WIRE
JOINT

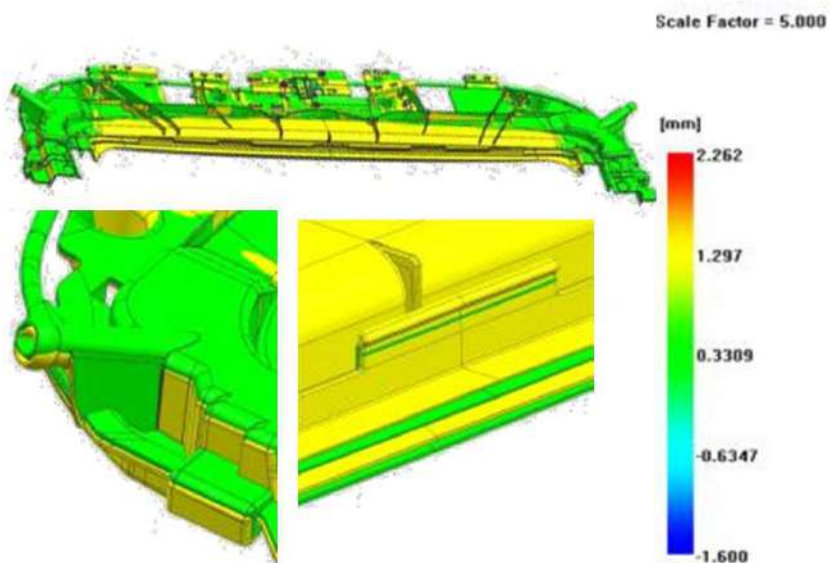

Engineering Compensation

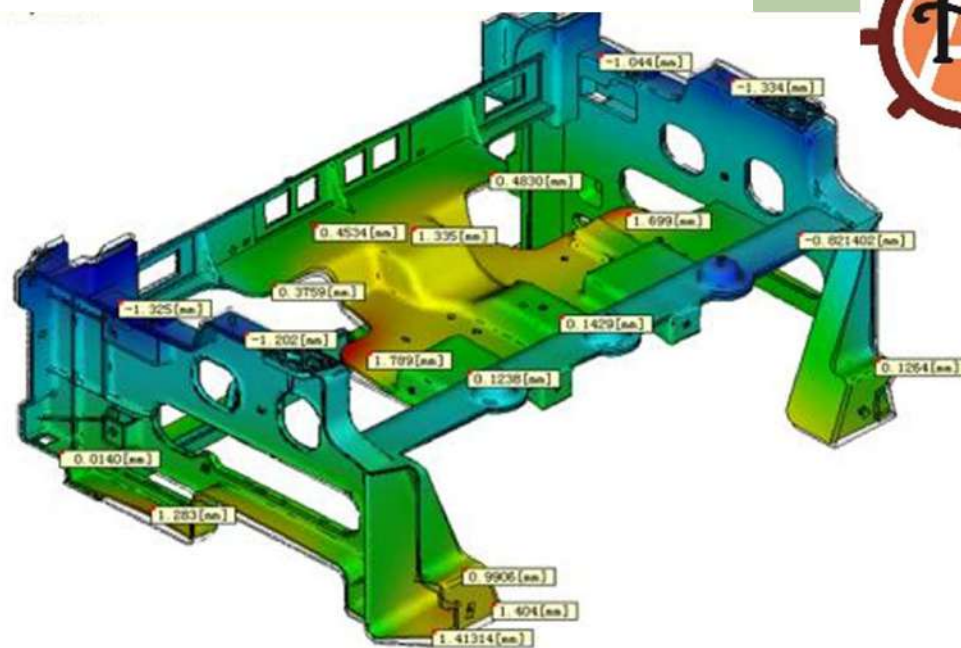

Mold Flow Analysis

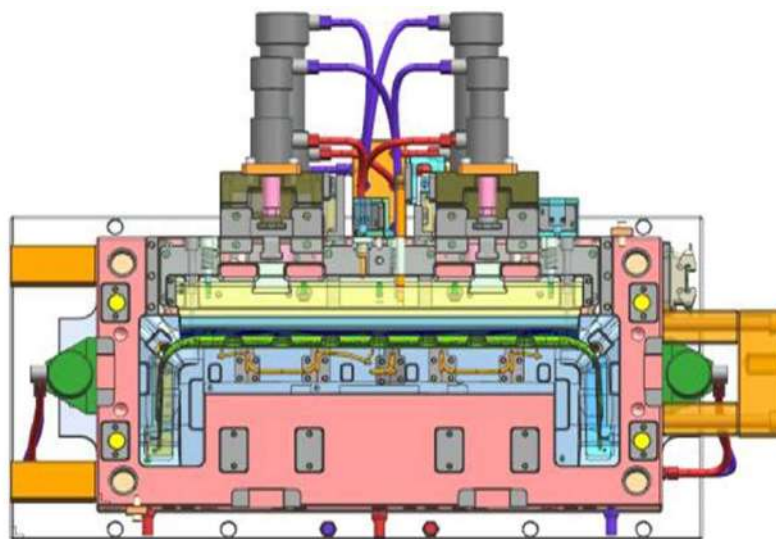

3D Tool Construction

- ◆ 6 sets of UG NX 8.5 licenses, 1 set of MoldFlow license
- ◆ Catia, Pro/E, Solidworks files are readable
- ◆ Reach experienced and special know-how in mold building with warpage parts!

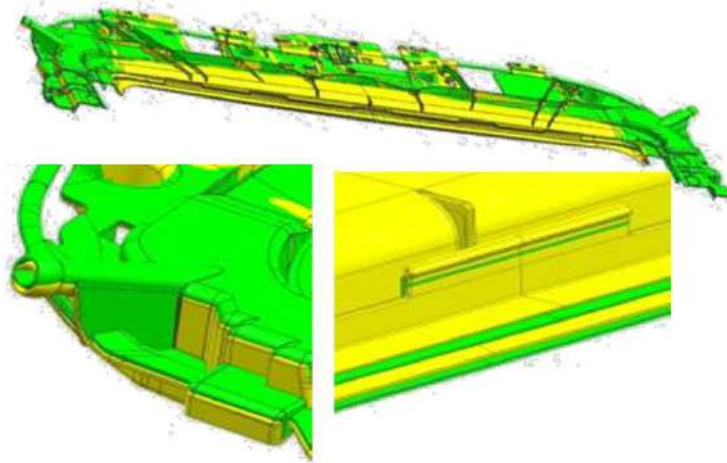

Compensation

充填时间
= 0.0209[s]

[s]

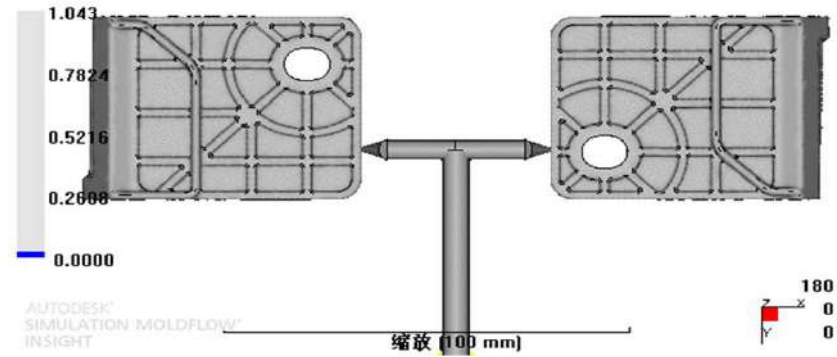

Mold Flow

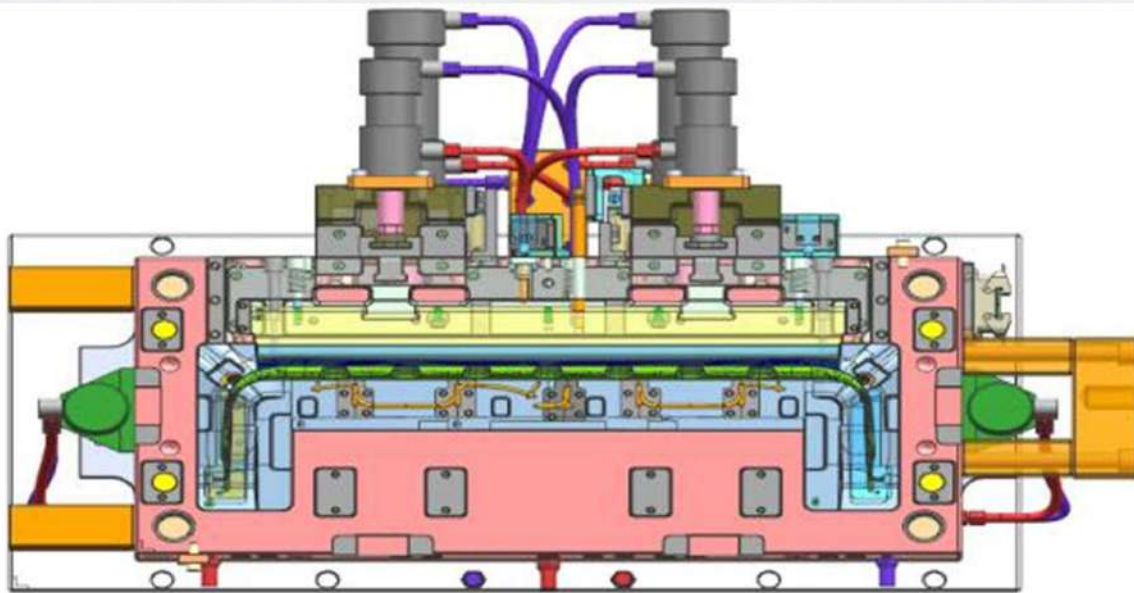

3D

All Latest Technology

- ◆ 6 sets of UG NX 8.5 licenses, 1 set of MoldFlow license
- ◆ Catia, Pro/E, Solidworks files are readable

OUR Equipment



CNC



Gun-Drilling



EDM



Assembly Shop



Spotting

OUR

Equipment

HPAI KUASU equips with 18 sets injection machines from 80T to 1,000T for the mold tryout and low volume production.

We can outsource the 1,000T 2K injection machine and 2,500T single-shot injection machine in one hour's driving way. We can provide the full dimensional inspection report, tryout parameter report, part samples, and long-time continuous production and tool testing video Etc. based on the customer request.



OUR Equipment

Milling Machines:	12sets
EDM:	11sets
Wire Cutting Machines:	3sets
Grinding Machine:	6sets
Gun-drilling Machine:	2sets
Spotting Machine :	1set
Tapping Machine:	2set
Tryout Machines:	5sets
CMM:	2set
Injection machines from 80T to 1,200Ton	

With CMM equipped directly into the CNC machines, it makes us able to have high quality performance on accurate steel cutting!



The heritage of rigorous and pragmatic tradition of behavior and thinking does not conflict with the mold making field with the application of the modern high-tech equipments. Just by taking the complements from both methods, Kuasu is well able to fulfill our commitment to the customers “high quality, high efficiency and lower cost”.

HPAI KUASU is an ISO/ TS16949 & ISO 9001-2015 Certified Company



OUR QUALITY

HPAI-KUASU is an ISO/ TS16949 & ISO 9001-2015 certified company, and all tools are built to the APQP standards, plus using German and Japanese steels, all components have to be closely inspected in climate-controlled environments prior to mold assembly to ensure the highest level of accuracy in every tool we built.

Our rigorous mold testing includes complete 1st article inspection report per customer supplied part drawing. In addition we can supply full capability studies to include dimensional PPAP report and Gage R&R testing. Upon the completion of sampling and part approval, each tool goes through a 100% final inspection before delivery.

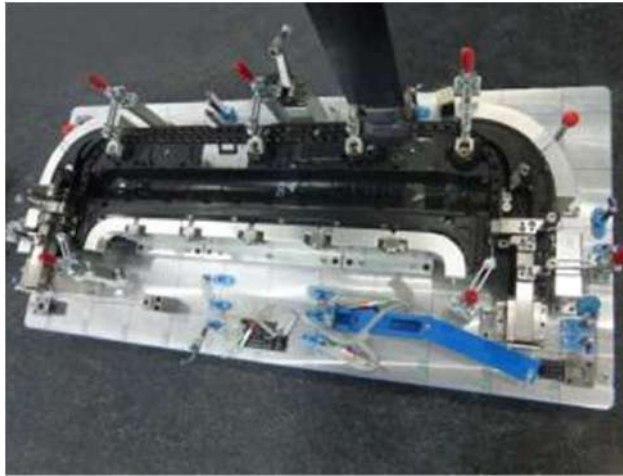

FLOWER

POT PRODUCTION



Automotive

Part-Roof system

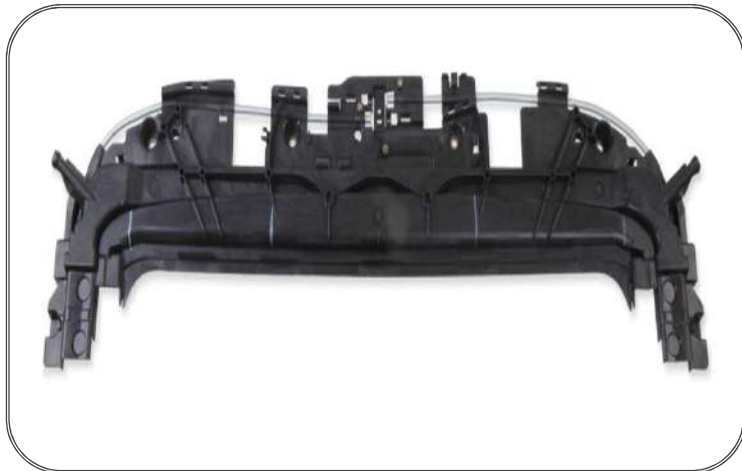

Automotive

Part-Door Carrier system



Automotive

Interior Parts



Automotive



Lights



Automotive

Part-Air Vents



Home

Appliance

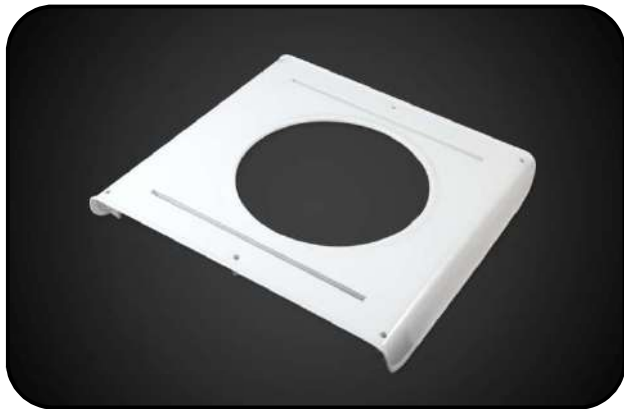



Stamping

Molds

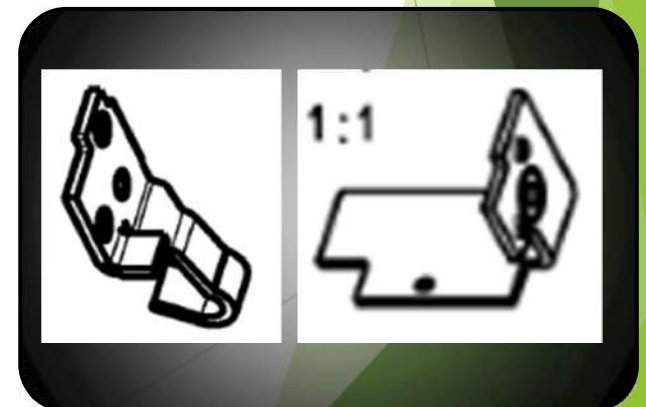
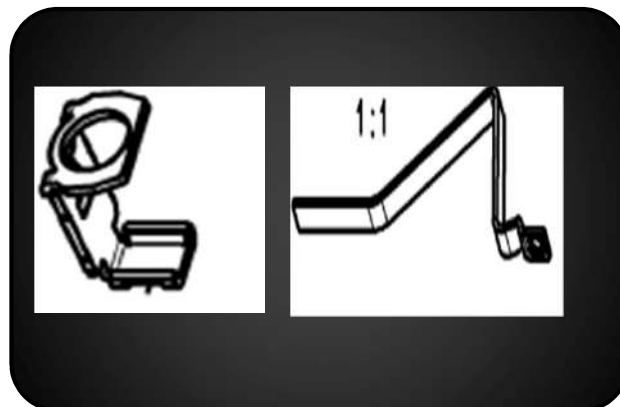
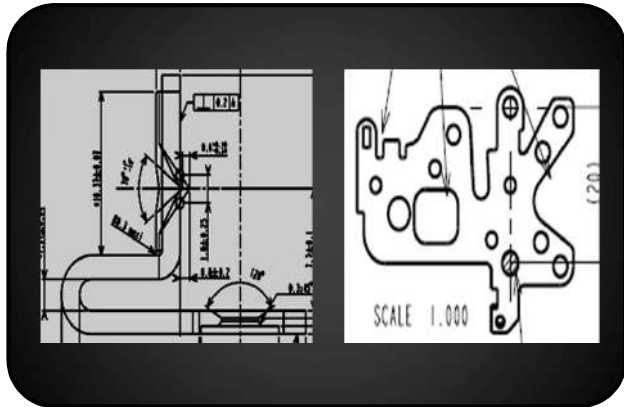
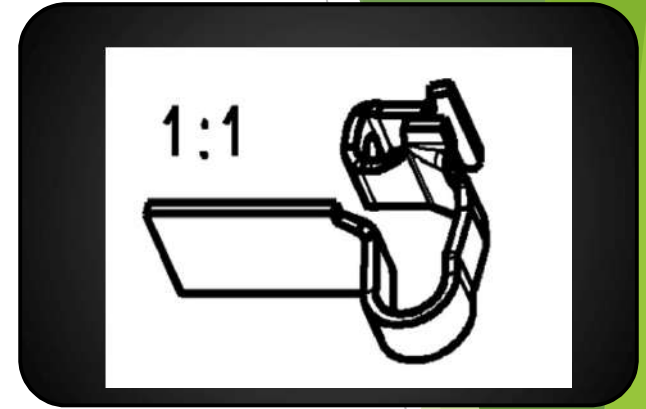
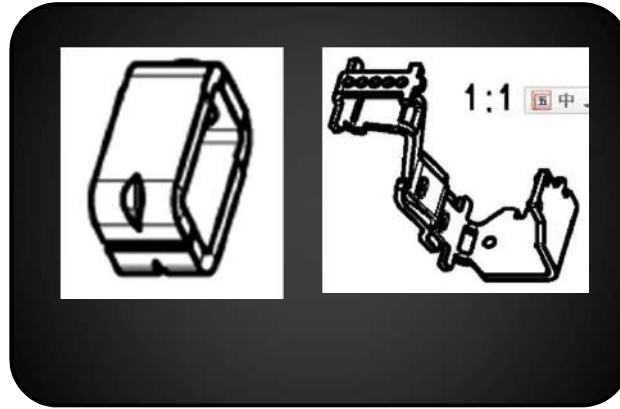

OUR

CUSTOMER



Government Sector:-



Private Sector



Note :-As per company policy private sector customer is confidential But just for your information mostly, we have OEM's, Tier-1, Tier-2 and direct customers also form all industries.

Now you





HARDIK PRECISION

Automotive Industries LLP

OUR

GST NO:-06AAJFH5478A1ZG

Address

[INDIA]

HARDIK PRECISION AUTOMOTIVE INDUSTRIES LLP.

Corporate office :-Plot No- 06, Gali No-5, E - Block Rayan Enclave,
Bhondsi, Sohona Road, Gurgaon Haryana India - 122102

Email:-Info@hpautomotives.com ; purchase@hpautomotives.com

Website :- www.hpautomotives.com ; www.hpil.in

Contact :-91+124-2980409 Mobile:-+91-9910507449



Skype ID:- Thakurajay001

[CHINA]

HPAI / Kuasu Precision Molds Co. Ltd.

Kangle RD | ShanXia cun Industrial zone |
Hengli Town | 523460 Dongguan | P.R. China

Email: Info@hpautomotives.com

Skype id:- Thakurajay001

Tel: 008676983723980



Mobile:-+91-9910507409



HARDIK PRECISION

Automotive Industries LLP



Some content may involve our customer's confidential information, more valuable information may not be disclosed in detail in our PPT. We suggest you contact us immediately,

or please mail us for further information.

Email Id :- Info@hpautomotives.com

purchase@hpautomotives.com

Mobile:-+91-1242980409

Mobile:-+91-9910507409

www.hpautomotives.com

Thanks